



OPERATION MANUAL

INSPECTORCAMERAS.COM

CONTENTS

INTRODUCTION	4
General Safety Rules	4
KNOW YOUR TOOL	5
Camera Head	5
Cable Unit	5
Control Box	5
Remote Control	5
Package Contents	5
SPECIFICATIONS	6-7
SETUP	
1. Install Cable Reel (fig. 6)	7
2. Install Control Box (fig. 7)	8
3. Install Camera Head (fig. 8)	8
4. Install Skids	9
23mm Camera Head	9
14mm Camera Head	9
5. Install SD Card	9
6. Turn on the DVR	9
FUNCTION GUIDE & DVR OPERATION	
1. Live Video	10
2. Video Options	10
3. Playback Mode	10
4. Playing Videos	11

CONTENTS

WIRELESS KEYBOARD OPERATION	11
Text Input	11
METER COUNTER OPERATION	12
PUSH CABLE & CAMERA OPERATION	13
Retrieving the Push Cable	13
BATTERY SAFETY & USE GUIDE	14
Using Safety	14
Using Guide	14
FCC Statement	14
CE	14
EMC	14
OTHER INFORMATION	15
Troubleshooting	15
SD Card Information	16
NOTES	17 - 18

INTRODUCTION

This SCOUT 3-PRO helps you locate and diagnose problems in a pipeline system.

The system is widely used in inspections of sewers, central air conditioning, chimneys, plumbing, building maintenance, pipe ventilation systems, and other places.

The following pages provide you with the information to understand the functions of the Scout 3-PRO camera and its accessories. This manual provides important notes to help you avoid accidents, damage, and injury.

GENERAL SAFETY RULES

Read all safety warnings and instructions. Failure to follow warnings and instructions may result in electric shock, fire, or injury.

1. Save this operation manual for future reference.
2. Do not operate this device in explosive atmospheres, such as in the presence of flammable liquids, gases, hazardous chemicals, superheated liquid, or heavy dust. It may create sparks that may ignite dust or fumes.
3. The camera head and the push cable are waterproof (when the camera is installed on the cable); however, the keyboard and the DVR inside the control box are not. Do not expose them to water or rain when the control box is open as this may cause internal damage.
4. Avoid using this device in environments of extreme cold, heat, or humidity as it may damage the device. Do not drop or press hard on the device.
5. Only qualified persons are allowed to repair this device. Service or maintenance performed by an unqualified person could result in injury or further damage.
6. Do not use this device in places where there is high-voltage equipment. This device doesn't contain high voltage insulation.

KNOW YOUR TOOL

This pipe inspection system includes the following four main parts: camera head, cable reel, frame, and control box.

The camera head includes bright white LEDs and a highly scratch-resistant sapphire lens cover.

The flexible stainless-steel spring allows the camera head to easily go through bends in the pipe.

The battery pack provides a long-lasting power supply for the system and the DVR monitor can record videos and take photos.

The open reel makes it very easy to clean.

CAMERA HEAD



23mm Camera Head

1. Sapphire Lens
2. PC lens
3. Stainless Steel Shell
4. Stainless Steel Spring
5. Camera O-ring
6. Gold Connector



14mm Camera Head

KNOW YOUR TOOL



CONTROL BOX

1. Power Button
2. SD card slot
3. Sunshade
4. Color LCD display
5. DC input
6. Meter counter zero-set button
7. Wireless keyboard
8. Aviation socket
9. Playback mode
10. Menu settings
11. Charging and power indicator
12. Image zoom/exit and return
13. Select left/rewind
14. Downward selection
15. Select right/fast forward
16. LED brightness
17. Remote control receiver
18. Start/stop recording
19. Photo shoot button
20. Image rotation
21. Upward selection
22. Confirmation/Pause
23. N/A- Future Use

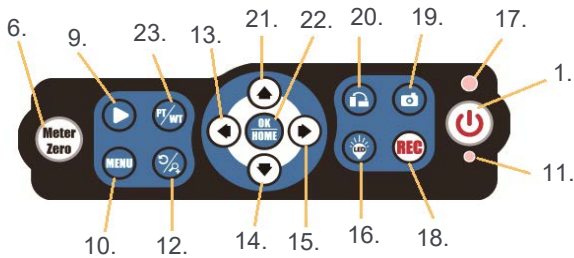

REMOTE CONTROL

1. Menu settings
2. Playback mode
3. N/A- Future Use
4. Image zoom /exit and return
5. Upward selection
6. Confirm / Pause
7. Select left / rewind
8. Select right / fast forward
9. Select downward
10. Image rotation
11. LED brightness
12. Start / stop recording
13. Photo shoot button

Remote Control

Figure 4

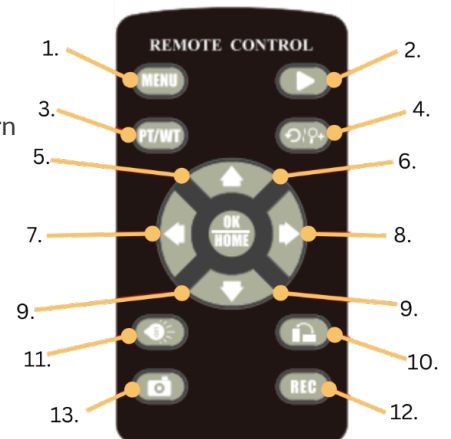

Cable Reel & Turntable

1. Cable Connector to camera head
2. Aviation Socket (connects to control box)
3. Push Cable



PACKAGE CONTENTS

1. Panel with DVR
2. Wireless keyboard
3. DC Charger
4. Car charger
5. Remote control
6. 46mm and 80mm skids for 23mm camera or 28mm skid for 14mm camera head
7. Screw (2x), nut (2x), and o-ring for 23mm camera head or o-ring for 14mm camera head
8. Hexagon Key
9. Screwdriver
10. Operation manual
11. Camera Head
12. Cable Reel
13. 6-pin Cable
14. Frame

SPECIFICATIONS

ITEM	PARAMETER		
General	Operating Temperature	-10 to 50C / 14 to 122F	
	Operating Humidity	30% RH to 90% RH	
	Storage Temperature	-20 to 60C / 4 to 140F	
	Power Adapter	Input: 100-240V AC, Output: 12V DC 1500mA	
	Measurements	20" x 15" x 13" (LxWxH)	
	Weight	27 lbs.	
Camera		Ø23MM CAMERA HEAD	Ø14MM CAMERA HEAD
	Sensor	1/30 CMOS	1/40 CMOS
	TV Line	420/480 TV Line	400 TV Line
	View Angle	120°	90°
	Focus Distance	20cm (approx)	6-8cm (approx)
	Depth of Field	100cm (approx)	20cm (approx)
	Camera Size	Ø23mm x 51mm (main body)	Ø14mm x 21mm (main body)
	Camera Length	155mm	125mm
	Front Lens	Sapphire	Sapphire
	Shell Material	304# Stainless Steel	304# Stainless Steel
	Lighting	Built-in 15x LED (white)	Built-in 4 x LED (white)
	Waterproof	20m water (with camera installed)	10m water (with camera installed)
	Power Supply	DC 9-15V	DC 9-15V
	Power Consumption	40 mA (LED off), 95 mA (LED on)	40 mA (LED off), 60 mA (LED on)
DVR	Screen	Super bright high-definition color 10" LCD screen	
	Screen Resolution	1024 x 600	
	Image	Support image rotation	
	Video Resolution	AHD 1080P / AHD 720P / CVBS D1	
	Video Encoding	High Compression / H 264	
	Photo Resolution	1920 X 1080	
	Audio Recording	Support local sound	
	Zoom	Support Zoom	
	External Memory	Support SD memory card up to 32GB	
	LED Driver	Built-in dimmer	
	Play Back	Video and photo, No audio	
	Language	English, Simplified Chinese, Traditional Chinese, Japanese, Korean, Russian German, French, Italian, Spanish, Portuguese, Thai	
	Power Supply	DC 6-12V input	
	Power Consumption	800 mA max	
	Battery Capacity	7.2V 6400 mAh Li-ion Battery	
Single Charge Work Time	~ 6 hours		
Charge Time	~ 10 hours		

SPECIFICATIONS

ITEM	PARAMETER			
Wireless Keyboard	Keyboard Compatibility	Support specific PC wireless keyboard		
	Typing Language	English		
	Max Characters	1000 Characters per page, support 9 pages		
	Hide Characters	Quick one key hiding (press "ESC")		
	Precision of Meter	Counter \pm 0.5%		
	Meter and Feet Switch	meter/feet/off		
	Re-set to Zero	Support		
	Power Consumption	40 mA@12v DC		
	Batteries	2x AAA		
Cable Reel	Cable Diameter	\varnothing 4.8mm	\varnothing 5.2mm	\varnothing 6.8mm
	Cable Length	30M/100'	30M/ 100'	40M/130'
Control Box	Size	14 x 10 x 6 inches (L x W x H)		
	Box Color	Black		

SETUP

To reduce the risk of injury or damage to the system, follow these procedures for proper assembly.

1. INSTALL CABLE REEL (FIG. 6)

Put the cable reel into the frame from the right side, then, place it in the proper direction with the 6-pin aviation socket toward the rear and tighten the screws. Pull out the cable with care, thread it through the hook, and lead the cable out.

Install Cable Reel

Figure 6

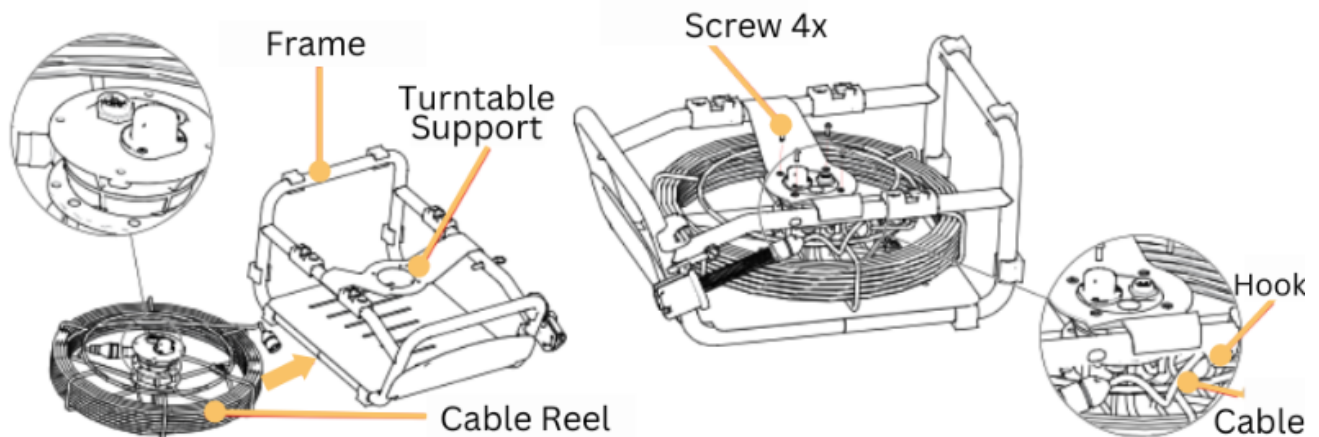

2. INSTALL CONTROL BOX (FIG. 7)

1. Plug one end of the 6-pin connection cable into the turntable aviation socket and tighten the thumb screw.
2. Clip the control box into the control box mounts on the frame and push back gently. You will feel it pop into place.
3. Place the lock pin through the control box slot and frame on the right side.
4. Connect the other end of the 6-pin connection cable with the aviation socket on the left side of the control box and tighten the thumb screw.

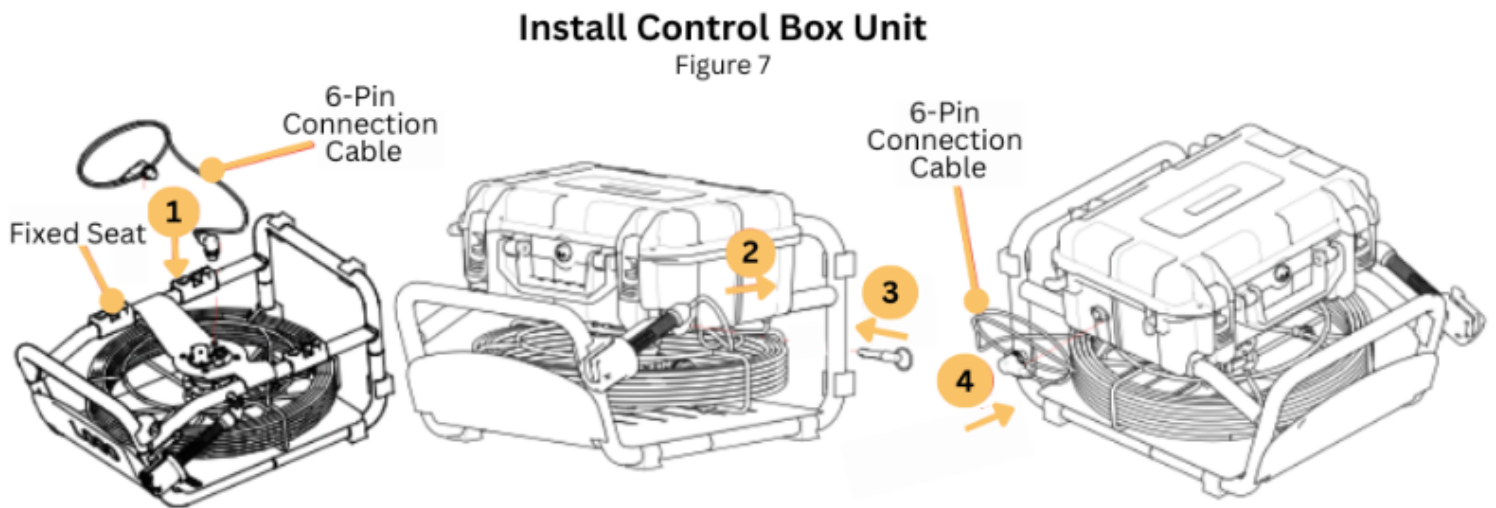

3. INSTALLING THE CAMERA HEAD (FIG.8)

Hold the push cable end firmly in one hand, then screw the camera onto the cable end hand tight. No tools are required.

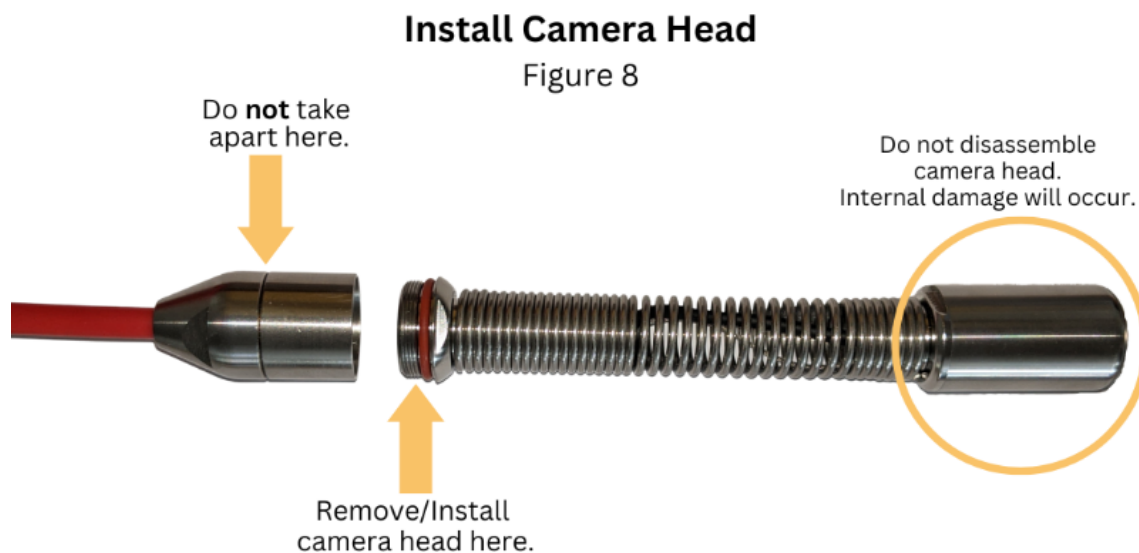

4. INSTALLING SKIDS

Skids are used to keep the camera head in the center of different sized pipes and to protect the camera head from damage. We recommend you always use skids.

23mm Camera Head

Install the 46mm skid (Figure 9). Mount the skid onto the stainless-steel camera head. Then, tighten the screw with a screwdriver.

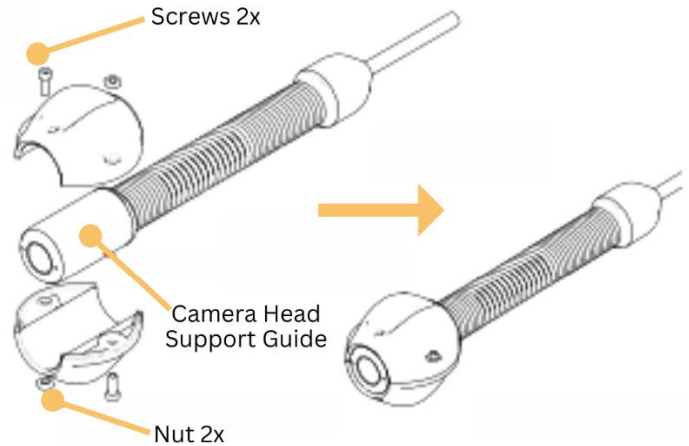
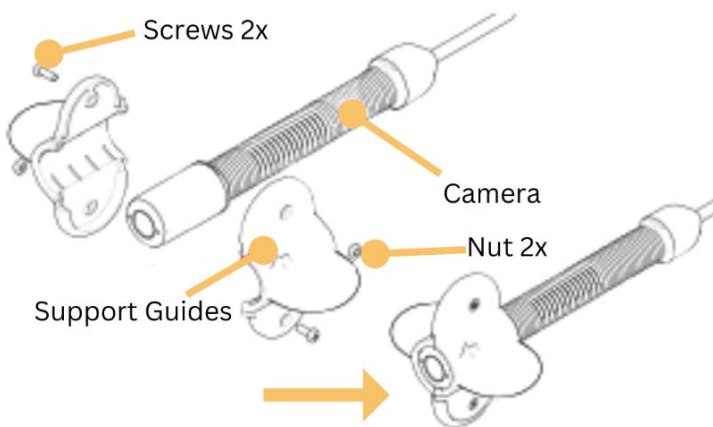

Figure 9

Figure 10



Install 80mm Skid (Figure 10).

Mount the 80mm skid onto the stainless steel camera head. Then tighten the screw with a screwdriver.

5. INSTALL SD CARD

The SD card needs to be inserted into the SD card slot with the contacts facing away from the user.

SEE SD CARD INFORMATION ON PAGE 15

6. TURN ON THE CONTROL BOX



FUNCTION GUIDE & DVR OPERATION

1. Live Video

Press  to turn on/off DVR to enter the live video mode

Press  to start/stop recording.

Press  to mirror and/or reverse the image.

Press  to adjust the brightness of the cameras LEDs.



Press  to take a picture. This feature also works while recording.

2. Video Option

Press  to enter the video option menu.

Press  and  to select items that you need

Press  to confirm the selection

Press  or  to change the value.

Press  to save the settings.

Press  to exit the video option and save.

Video Seg: 10min/ 20min/30min. Set 10-30min to restrict the file recording length.



Older files will be recorded over with new files when the SD card is full. Press OK to select video length.

Sound: Turn on/off the voice recording.

Timestamp: Enable/Disable time stamp on screen.

3. Playback

Press  to enter the playback. The user can browse, preview, and playback media files.

Press  and  to browse and select media files.

Press  to confirm the selection and preview the media file.

Press  to preview the previous file.

Press  to preview the next file.

Press  to playback video.

Press  to enter the play settings.

4. PLAYING VIDEO

To pause/play movie, press .

Press the  to stop playing movie.

Press  to rewind.

Press  to fast forward.

Press  to set the speed of rewinding/forwarding.

NOTE: Audio will not play back



The following items are in the setup menu:

- Format: format SD card.
- LCD: LCD brightness.
- Language: English, German, French, Spanish, Italian, Chinese, Japanese, Russian, Portuguese.
- Sys. Reset: Reset all settings.
- Light frequency, 50Hz / 60Hz, specifying your ambient light frequency.
- Date input: To set date and time.

Wireless Keyboard & Text input

- The wireless keyboard text writer is used to type characters that display on the screen, the characters can be displayed on a recorded video or a captured photo.
- Supports 1000 characters per page, supports 9 pages
- Type the characters with the wireless keyboard. Use the arrow keys to move the cursor. the backspace key to delete, and the enter key to add a new line
- Use the Esc key to hide or show all characters. Press Ctrl + Del to delete all characters.
- You can type and edit characters while recording. The typing and editing will be recorded in the video files.
- The typed characters will be stored in the memory.
- The wireless keyboard dongle is inserted into the control box below the SD slot to the right of the screen.

METER COUNTER OPERATION

- Press the  button to set the meter to zero .
- To change the unit of length or the total length of the push cable, press and hold the  button while powering on the DVR monitor. When the "L:5-" flashed us the up and down arrows to select the unit of length, press  to save and exit.

NOTE 1: The deviation of the MC will increase if the total length is not correct. Select the correct total length to decrease the deviation. Use this function to change the displayed total length when the push cable is cut off for more than 3 meters.

NOTE 2: Turn on the system before pulling out the push cable from the cable reel. This will decrease the deviation of the MC.

PUSH CABLE & CAMERA OPERATION

- 1** Always wear rubber gloves while operating the camera for health/safety reasons. Properly positioning the cable reel will save time and effort to push the cable.
- When pushing, the end of your stroke should be as close to the entry/cleanout as possible. Standing too far back with excess cable between your hands and the entry may cause the cable to fold on itself and damage the cable.
 - Try to keep the push cable away from the sharp edges of a pipe entry as this may cause damage. If the camera does not seem to go any further, do not force the camera into the pipe. Try another entry if possible.

NOTE: Hands should be close to the line opening. Don't continue to push if the cable catches on the edge of the entry to the pipe.

- 2** Always try to run water down the pipe undergoing inspection. This will keep the system much cleaner and allow you to push with less friction. If the water is preventing you from seeing an area of importance, temporarily turn it off.
- 3** When pushing the cable through the pipeline, be steady and slow, only going a short distance at a time. Keep your hands at the entrance point to control the push cable and prevent it from sticking, scratching, or bending.

- 4 When inspecting a pipe, most of the time a slow steady push through the system works best. At changes in direction, it is usually necessary to give a little extra push around the bends. Back the camera head approximately 8" (20cm) from the bend, if necessary, and give it a quick push, popping the camera through the turn, using the least amount of force required. Try to be as gentle as possible, and avoid trying to hammer or snap the camera head through corners. After some practice, you may learn that the best way to inspect a section of pipe is to push through quickly. Then draw the camera back slowly and evenly.
- 5 Make sure the sapphire window is clean prior to entry. Some users claim that a slight film of detergent on the lens minimizes the possibility of grease sticking to the camera head. If necessary, take advantage of any standing water in the pipe to wash the front of the camera by jiggling it in the water.
- 6 When you place the camera head into the pipe, it may be necessary to adjust the LED settings to maximize the picture quality.
- 7 The system can travel through multiple 45- and 90-degree bends. Do not try to force it through a P-trap or tee if there is a large amount of resistance.

NOTE: Do not try to use the camera head to clear obstructions. This system is a diagnostic tool, not a drain cleaner. Using the camera head to clear obstructions could damage the camera head or cause it to get caught on the obstruction.



Improper Operation
Figure 14

- 8 Do not attempt to remove or store the push cable on the reel solely by turning the reel itself. You can manually push or pull the cable from the reel to wind or unwind it.
- 9 If the camera sits in a pipe, or an enclosed environment, heat will build-up. This may lead to the camera head overheating which will cause fuzzy lines to appear on the monitor. If this happens, turn off the system, remove the camera from the pipe and let the camera head cool for 10 to 15 minutes. Running water into the line will also help cool the camera head. Always use the minimum illumination required to maximize picture quality and to avoid excessive heat build-up.

NOTE: The camera head can get HOT! When finished with your inspection, or if taking a prolonged break in the middle of the inspection, turn the system off.

PUSH CABLE & CAMERA OPERATION

Retrieving the Push Cable

- 1 Once the inspection has been completed, pull the push cable back with a slow, steady force. Do not exert excessive force as this could damage the camera or push cable. The push cable may get hung up while being retrieved and may need to be manipulated as done during insertion.
- 2 While retrieving the push cable, running water can be used to easily remove the cable from the pipe. As you retrieve the camera head, you can use wipes to clean the cable.

NOTE: NEVER USE SOLVENTS to clean any part of the system. Substances like acetone and other harsh chemicals can cause cracking of the o-ring, which could affect the waterproofing.

- 3 Store the push cable on the cable reel. One hand holds the push cable, the other hand holds the machine in place. Slowly push the cable back into the reel. The reel will rotate holding the cable inside.

NOTE: Push the cable a little at a time. Pushing too much of the cable all at once can cause it to bend or brake.

BATTERY SAFETY & USE GUIDE

USER SAFETY

Read the following battery precautions before charging the camera to reduce the risk of electrical shock.

- Recharge batteries with the provided accessory charging units.
- Always check the power units before using the equipment to be sure there it is working properly.
- Never connect the car charger to any 24-volt cigarette lighter slot. This will damage the battery and DVR.
- Do not short circuit; it may cause a fire or electrical shock.
- Do not charge the battery in the rain or wet conditions. Water entering the charger will increase the risk of electrical shock.
- If the charger and battery are damaged, do not use them. This may cause electrical shock.
- Don't disassemble the case, only a qualified repair person can repair and provide maintenance.
- Properly dispose of the battery. Exposure to high temperatures can cause the battery to explode.
- Please follow all applicable battery disposal regulations.

USER GUIDE

Follow the steps below to properly charge your equipment.

- Power indicator LED will be red during charging and will be green when charged fully.
- The camera needs approximately 10 hours to charge the battery
- fully. You can use a power adapter or car charger to charge the battery.

FCC Statement

This device complies with part 15 of the FCC Rules. Operation is subject to the following two conditions:

This device may not cause harmful interference.

This device must accept any interference received, including interference that may cause undesired operation.

CE This product complies with standards including Low Voltage Device Directive 73/ 23/EEC;

EMC Directive 89/ 336/EEC. It passed the subject tests by the authority concerned and is authorized to bear CE mark.

Troubleshooting

Problem	Probable fault location	Solution
Meter is not accurate	Cable length not properly set	Set cable length using Meter Counter Operations (Pg 12)
	Not set to zero	Press  to reset to zero
No image	Cable connection is faulty or loose	Check cable connection, clean, and reconnect if necessary
	Camera connection is dirty	Clean the rings and pins
	Wrong SD memory card	Turn off power and replace SD card
	Broken Cable	Inspect cable for damage; replace if broken
DVR Cannot boot	No power	Recharge
	Transient short circuit in the cable/camera head causes the battery to short circuit for protection.	Recharge the DVR more than 2 hours with adaptor or car-charger to activate the battery.
Cannot input Characters	The wireless keyboard low battery	Change battery
	Wireless Keyboard or Receiver is faulty	Check the Keyboard Receiver on a PC/ Check the battery
The deviation of Meter Count is more than 0.5%	Wrong length selected	Re-select the correct total length. Set cable length using Meter Counter Operations on Page 12.
	Pull out the cable more than 3 meters before turning on the system.	Turn on the system before pulling out the push cable from the cable reel.

SD CARD INFORMATION

Your system has come equipped with a 16GB or 32GB Max Class 10 SD card. It is very important to familiarize yourself with your SD card.

In the future you will likely need to acquire new cards; it is crucial to follow these few simple guidelines to prevent losing your pictures and video and to prevent software corruption within your system's computer



1. Size: We recommend the only cards to be used in your inspection system are 16GB or 32GB

- While it may be tempting to grab a larger card, you are running the risk of software corruption. This is because SD cards have a certain amount of programming saved on them; to auto-format, recognize date & time, etc.
- Cards in the 16-32GB bracket, also known as SDHC cards have a “FAT32” file system installed on them; whereas most cards above that size, and even some 32GB cards, are classified as “SDHX” cards and have the “exFAT” file system installed.
- Your inspection system cannot read cards in the “exFAT” format. If these are installed into the machine you will likely be met with a “Cannot Format” error message.
- Smaller cards may work, but increase the risk of auto-write over

2. Speed: Our systems require using only a Class 10 speed

- SD cards come in “Write Speeds” measured in Megabytes per second. You can find them in 2mbps, 4, 6, or 10.
- The higher the Class/Speed the faster your system will be able to save (or “write”) your pictures and videos to the card.
- The faster you can save data to your card, the less likely you are to “lose” a picture or video, especially when hurriedly leaving your job site while trying to save a large video.
- Though, you should always double-check that your pictures and videos have been recorded and saved properly before packing up.

3. Style: Please make sure you are using a singular, solid body SD card; Not a mini- or micro-SD card

- Adapter- style SD cards may work with your system, but they highly increase the risk of corruption of the media files, and failure of the SD card itself (reading/writing files).

When installing a fresh SD card into your inspection system, please make sure the card is not locked.

Each card has a tab on the side, make sure the sliding tab is not in the locked position. Then make sure the card is inserted with the contacts facing the display screen, and the “missing corner” on the bottom.



Always inspect cards for damage or oxidation prior to use.

Once a fresh SD card has been installed into your inspection system a message will trigger to format the card.

Simply hit “OK” to format the card. After a moment another message will pop up saying format complete with a check mark.

NOTES

NOTES



CONTACT US



Inspector Cameras

8030 South Willow St. Bldg #1 Unit #3
Manchester, NH 03103



sales@inspectorcameras.com
service@inspectorcameras.com



(603) 267-0400



<https://inspectorcameras.com>